

APPENDIX C

GUIDELINES FOR UPGRADING OF EXISTING BRIDGERAILS

THIS PAGE INTENTIONALLY LEFT BLANK

Appendix C

Guidelines for Upgrading of Existing Bridgerails

TABLE OF CONTENTS

Appendix	Title
C1	Life-Cycle Benefit-Cost Analysis Procedure for Determining the Need for Bridgerail Upgrading
C2	Existing INFTRA Bridgerails and Corresponding Severity Indices

THIS PAGE INTENTIONALLY LEFT BLANK

APPENDIX C1

LIFE-CYCLE BENEFIT-COST ANALYSIS PROCEDURE FOR DETERMINING THE NEED FOR BRIDGERAIL UPGRADING

THIS PAGE INTENTIONALLY LEFT BLANK

Appendix C1

Life-Cycle Benefit-Cost Analysis Procedure for Determining the Need for Bridgerail Upgrading

TABLE OF CONTENTS

Appendix	Title	Page Number
HC1.1	Life-Cycle Benefit-Cost Analysis Procedure	H-APP-C1-1
HC1.2	Examples – Upgrading Existing Bridgerail	H-APP-C1-8

THIS PAGE INTENTIONALLY LEFT BLANK

HC1.1 Life-Cycle Benefit-Cost Analysis Procedure

The need to upgrade an existing bridgerail is determined from a life-cycle benefit-cost analysis procedure. The Technical Summary provided in this appendix outlines the analysis procedure to be used for determining the need to upgrade Alberta Infrastructure and Transportation’s existing bridgerails. The basis of this procedure comes from the 2003 INFTRA Report entitled “*Guidelines for Upgrading of Existing Bridgerails/Approach Rail Transitions in Alberta.*” Unlike the original document, upgrading of existing approach rail transitions has been excluded from this Technical Summary. Upgrading of existing approach rail transitions is described in Appendix D because the methodology has been extended in the form of Warrant Charts.

The steps to carry out the life-cycle benefit-cost analysis procedure for existing bridgerails are as follows:

1. Select the bridgerail upgrading alternatives to be considered. Figure HC2.1 (Appendix C2) shows Alberta Infrastructure and Transportation’s commonly used existing bridgerails. Figures HC2.2-1 and HC2.2-2 (Appendix C2) show recommended upgrading concepts for these bridgerails. Other bridgerail upgrades may be used if justified by site specific requirements. In situations where standard bridgerail upgrading drawings have been developed by INFTRA, such as the Vertical Bar/Horizontal Rail Bridgerails (S-1750-07 to S-1752-07) and the Single Layer Deep Beam Bridgerail (S-1720-07), these upgrading drawings shall be used unless otherwise approved by INFTRA. The bridgerail upgrading alternatives considered should include the “do nothing” alternative.
2. Determine the severity indices for each existing bridgerail and upgrading alternative being considered. Severity Indices (SI) for existing INFTRA bridgerails are shown in Figure HC2.1 (Appendix C2); SI values for recommended bridgerail upgrades are shown in Figures HC2.2-1 and HC2.2-2 (Appendix C2).

For Vertical Bar/Horizontal Rail Bridgerails, Standard INFTRA bridge drawings S-1750-07 to S-1752-07 provide the upgrading details that should be used for this type of bridgerail. SI values for upgraded Vertical Bar/Horizontal Rail Bridgerails are provided below:

Design Speed (km/h)	50	60	80	100	110	120
Severity Index	2.0	2.1	2.5	3.0	3.3	3.7

Note: The SI values in Figure HC2.1 for existing 1) Single Layer Deep Beam Bridgerail on Participating Curb and 2) Double Layer Deep Beam Bridgerail on Participating Curb are different than the SI values presented in the INFTRA Report entitled “*Guidelines for Upgrading of Existing Bridgerails/Approach Rail Transitions in Alberta.*” The SI values for the higher design speeds have been increased for these two types of bridgerails to be more consistent with the SI values assigned to other bridgerail types.

3. Determine the “present worth” of the collision costs for each bridgerail upgrading alternative being considered, including the “do nothing” alternative, using the following equation:

$$PWCC = R * k_c * k_g * P * k_m * k_s * AC * L * KC/1000$$

Where:

PWCC	= present worth of the collision costs (for one side of the bridge only)
R	= basic encroachment rate (Table HC1.1, see note below)
k_c	= highway curvature factor (Table HC1.2)
k_g	= highway grade factor (Table HC1.3)
P	= lateral encroachment probability (Table HC1.4)
k_m	= highway multi-lane factor (Table HC1.5)
k_s	= bridge height and occupancy factor (Table HC1.6)
AC	= cost per collision for severity index (Table HC1.7)
L	= length of bridgerail for which collision costs are being determined (m)
KC	= present worth conversion factor (Table HC1.8). Annual collision costs are converted to present worth for a discount rate of 4% and a traffic growth rate of 2%. The project life used to determine KC should not exceed 20 years. A project life of less than 20 years should be used if the bridgerail deck and/or curb are expected to be replaced within this time period.

Note: The encroachment rates shown in Table HC1.1 are based on a conservative estimate of the encroachment curves from an older RSAP publication that has since been superseded, except that the values have been divided by a factor of 2 (for undivided highway – 2 lanes) or 4 (for divided highways – 4 lanes) to obtain the encroachment rates on one side of the highway only. The encroachment rates in Table HC1.1 have been further divided by a factor of 1.6 to obtain the encroachment rates on one side of the highway from the adjacent traffic lane only. The factor of 1.6 is taken from Table HC1.5 for a design speed of 100 km/h.

It should be pointed out that the encroachment rates from Table HC1.1 have since been superseded by the encroachment frequency curves shown in Figure H3.11 of this manual. While the encroachment frequencies in Figure H3.12 are considered to be more accurate, the older set of encroachment frequency data in Table HC1.1 should be used to be consistent with the 2003 INFRA report entitled “Guidelines for Upgrading of Existing Bridgerails/Approach Rail Transitions in Alberta”.

4. Determine the present worth of the bridgerail upgrading costs, including any associated deck and curb upgrading costs. These costs are determined for one side of the bridge only to be consistent with the collisions costs. The upgrading costs must then be multiplied by an adjustment factor to convert them into year 2000 dollars since the yearly assumed collision costs are based on societal costs in year 2000 dollars. For reference, the recommended factor for converting year 2007 costs to year 2000 costs is assumed to be 1.5. The magnitude of this conversion factor for life-cycle benefit-cost analyses carried out after year 2007 should be chosen accordingly. The societal costs for the three different collision classes – fatal, injury, and property damage only, are presented in Section H.3.3.1 of the RDG.
5. Determine the “present worth” of each bridgerail upgrading alternative being considered, including the “do nothing” alternative, by adding the bridgerail upgrading cost (if any) to the “present worth” of the annual collision costs. Select the upgrading alternative with the lowest “present worth” using a discount rate of 4%.

TABLE HC1.1 Basic Encroachment Rates (R)

Traffic Volume (AADT) ¹	Basic Encroachment Rate ² (encroachments / km / year / side of highway)	
	Undivided Highways	Divided Highways
0	0.00	0.00
1000	0.34	0.13
2000	0.61	0.23
3000	0.80	0.30
4000	0.91	0.36
5000	0.97	0.38
6000	0.92	0.38
7000	0.76	0.41
8000	0.66	0.43
9000	0.66	0.45
10,000	0.67	0.48
11,000	0.70	0.50
12,000	0.72	0.53
13,000	0.74	0.56
14,000	0.76	0.59
15,000	0.79	0.62
16,000	0.81	0.66
17,000	0.83	0.69
18,000	0.86	0.72
19,000	0.88	0.75
20,000	0.91	0.79
21,000	0.93	0.83
22,000	0.95	0.87
23,000	0.98	0.91
24,000	1.00	0.95
25,000	1.02	0.99

NOTES:

¹ The Average Annual Daily Traffic (AADT) is consistent with the traditional definition as being the total volume of traffic (vpd) during a year, in both directions, divided by 365 days in a year.

² Basic Encroachment Rates are the encroachment rates towards one side of the highway from the adjacent traffic lane only.

TABLE HC1.2 Highway Curvature Factors (k_c)

Radius of Curve (m)	Bridgerail on Outside of Curve	Bridgerail on Inside of Curve
≤ 300	4.00	2.00
350	3.00	1.65
400	2.40	1.45
450	1.90	1.30
500	1.50	1.15
550	1.20	1.05
≥ 600	1.00	1.00

TABLE HC1.3 Highway Grade Factors (k_g)

Grade (%) ¹	Highway Grade Factor
≥ -2	1.00
-3	1.25
-4	1.50
-5	1.75
≤ -6	2.00

¹ The grade used is for the direction of travel when approaching the bridgerail.

TABLE HC1.4 Lateral Extent of Encroachment Probabilities (P)*

Shoulder Width (m)	Design Speed (km/h)					
	50	60	80	100	110	120
0.00	1.0000	1.0000	1.0000	1.0000	1.0000	1.0000
0.50	0.6798	0.7393	0.8242	0.8901	0.9102	0.9213
1.00	0.5203	0.5919	0.6877	0.7731	0.8073	0.8397
1.50	0.4132	0.4921	0.5956	0.6794	0.7192	0.7542
2.00	0.3319	0.4135	0.5283	0.6056	0.6454	0.6842
2.50	0.2698	0.3497	0.4720	0.5472	0.5849	0.6233
3.00	0.2209	0.2973	0.4217	0.4983	0.5344	0.5723
3.50	0.1822	0.2544	0.3766	0.4555	0.4906	0.5274
4.00	0.1506	0.2179	0.3367	0.4174	0.4515	0.4881
4.50	0.1248	0.1874	0.3012	0.3828	0.4158	0.4520
5.00	0.1035	0.1613	0.2700	0.3516	0.3834	0.4189

* See AASHTO 1996 Roadside Design Guide for more extensive table providing values up to 120 feet offset.

TABLE HC1.5 Highway Multi-Lane Factors (k_m)

Design Speed (km/h)	Highway Multi-Lane Factor
50	1.20
60	1.30
80	1.45
100	1.60
110	1.65
120	1.70

Note: The Multi-Lane Factor accounts for encroachments from all other lanes.

TABLE HC1.6 Bridge Height and Occupancy Factors (k_s)

Bridge Height Above Ground (m)	Bridge Height and Occupancy Factor	
	Low Occupancy Land Use	High Occupancy Land Use ¹
≤ 5.0	0.70	0.70
6.0	0.70	0.80
7.0	0.70	0.90
8.0	0.70	1.00
9.0	0.80	1.15
10.0	0.95	1.25
11.0	1.05	1.35
12.0	1.20	1.50
13.0	1.30	1.60
14.0	1.45	1.70
15.0	1.55	1.85
16.0	1.70	1.95
17.0	1.80	2.05
18.0	1.95	2.20
19.0	2.05	2.30
20.0	2.20	2.40
≥ 24.0	2.70	2.85

¹ High Occupancy Land Use includes highways or railways beneath bridges, as well as water deeper than 3.0 metres.

TABLE HC1.7 Relationship of Severity Index and Cost per Collision (AC)

Severity Index	Cost (year 2000 dollars)
1	\$ 20,400
2	\$ 37,500
3	\$ 74,600
4	\$ 110,800
5	\$ 186,000
6	\$ 317,000
7	\$ 470,200
8	\$ 720,000
9	\$ 1,030,000
10	\$ 1,340,000

TABLE HC1.8 Present Worth Conversion Factors at 2% Traffic Growth Rate (KC)

Project Life (years)	4% Discount Rate, KC	Project Life (years)	4% Discount Rate, KC
1	0.971	11	9.712
2	1.924	12	10.496
3	2.858	13	11.266
4	3.774	14	12.020
5	4.672	15	12.760
6	5.554	16	13.486
7	6.418	17	14.198
8	7.266	18	14.896
9	8.097	19	15.580
10	8.912	20	16.252

HC1.2 EXAMPLES – UPGRADING EXISTING BRIDGERAIL

EXAMPLE 1 – BRIDGE #1

BACKGROUND INFORMATION

- highway is a two lane undivided highway;
- highway design speed is 100 km/h;
- highway is on a horizontal curve with radius of 450 metres;
- highway is on a vertical curve with a maximum grade less than 2%;
- bridge deck is 13.0 metres above stream bed (water depth less than 3.0 metres);
- bridge shoulder width is 0.9 metres;
- existing bridgerail is a 450 metre long horizontal rail bridgerail on safety curb (typical on both sides of bridge);
- existing approach rail transition is deep-beam guardrail unconnected to bridgerail;
- AADT is 1700; and
- remaining life of bridge deck and curbs is a minimum of 20 years.

BRIDGERAIL UPGRADING

Alternative 1 “Do-Nothing”

Input Variables:

- $R = 0.53$ (interpolated from Table HC1.1)
- $k_c = 1.9$ (see Table HC1.2)
- $k_g = 1.0$ (see Table HC1.3)
- $P = 0.7965$ (interpolated from Table HC1.4)
- $k_m = 1.60$ (see Table HC1.5)
- $k_s = 1.30$ (see Table HC1.6)
- $SI = 3.6$ (see Figure HC2.1(a), Appendix C2)
- $AC = \$96,300$ (interpolated from Table HC1.7)
- $KC = 16.252$ (see Table HC1.8)
- $L = 450$ m

Present Worth of Collision Costs (PWCC):

$$PWCC = 0.53 \times 1.9 \times 1.0 \times 0.7965 \times 1.60 \times 1.30 \times \$96,300 \times 450 \text{ m} \times 16.252/1000 = \$1,175,000$$

Present Worth of Upgrading Costs (PWUC):

$$PWUC = \$0$$

Total Present Worth (TPW):

$$TPW = \$1,175,000 + \$0 = \$1,175,000$$

Alternative 2 "Upgrade Existing Bridgerail Based on Figure HC2.2(a) (Appendix C2)"

Input Variables:

- R = 0.53 (interpolated from Table HC1.1)
- $k_c = 1.9$ (see Table HC1.2)
- $k_g = 1.0$ (see Table HC1.3)
- P = 0.7965 (interpolated from Table HC1.4)
- $k_m = 1.60$ (see Table H C1.5)
- $k_s = 1.30$ (see Table HC1.6)
- SI = 3.3 (see Figure HC2.2(a), Appendix C2)
- AC = \$85,400 (interpolated from Table HC1.7)
- KC = 16.252 (see Table HC1.8)
- L = 450 m
- Assumed cost to upgrade the bridgerail is \$250/m in year 2000 dollars

November 2007

Present Worth of Collision Costs (PWCC):

$$PWCC = 0.53 \times 1.9 \times 1.0 \times 0.7965 \times 1.60 \times 1.30 \times \$85,400 \times 450 \text{ m} \times 16.252/1000 = \$1,042,000$$

Present Worth of Upgrading Costs (PWUC):

$$PWUC = 450 \text{ m} \times \$250/\text{m} = \$113,000$$

Total Present Worth (TPW):

$$TPW = \$1,042,000 + \$113,000 = \$1,155,000$$

Conclusion: The "Upgrading" alternative is the recommended alternative because it has the lowest total present worth.

EXAMPLE 2 – BRIDGE #2

BACKGROUND INFORMATION

- highway is a two lane undivided highway;
- highway design speed is 100 km/h;
- highway is on tangent horizontal alignment;
- highway is on a vertical grade of 0.8%;
- bridge deck is 7.5 metres above stream bed (water depth less than 3.0 metres);
- bridge shoulder width is 1.8 metres;
- existing bridgerail is a 110 metre long single layer deep-beam bridgerail on safety curb (typical on both sides of bridge);
- existing approach rail transition is deep-beam guardrail unconnected to bridgerail;
- AADT is 2500; and
- remaining life of bridge deck and curbs is a minimum of 20 years.

BRIDGERAIL UPGRADING

Alternative 1 “Do-Nothing”

Input Variables:

- $R = 0.71$ (interpolated from Table HC1.1)
- $k_c = 1.0$ (see Table HC1.2)
- $k_g = 1.0$ (see Table HC1.3)
- $P = 0.6351$ (interpolated from Table HC1.4)
- $k_m = 1.60$ (see Table HC1.5)
- $k_s = 0.70$ (see Table HC1.6)
- $SI = 3.8$ (see Figure HC2.1(c), Appendix C2)
- $AC = \$103,600$ (interpolated from Table HC1.7)
- $KC = 16.252$ (see Table HC1.8)
- $L = 110$ m

Present Worth of Collision Costs (PWCC):

$$PWCC = 0.71 \times 1.0 \times 1.0 \times 0.6351 \times 1.60 \times 0.70 \times \$103,600 \times 110 \text{ m} \times 16.252/1000 = \$94,000$$

Present Worth of Upgrading Costs (PWUC):

$$PWUC = \$0$$

Total Present Worth (TPW):

$$TPW = \$94,000 + \$0 = \$94,000$$

Alternative 2 "Upgrade Existing Bridgerail Based on Figure HC2.2(g) (Appendix C2)"

Input Variables:

- R = 0.71 (interpolated from Table HC1.1)
- $k_c = 1.0$ (see Table HC1.2)
- $k_g = 1.0$ (see Table HC1.3)
- P = 0.6351 (interpolated from Table HC1.4)
- $k_m = 1.60$ (see Table HC1.5)
- $k_s = 0.70$ (see Table HC1.6)
- SI = 3.3 (see Figure HC2.2(g), Appendix C2)
- AC = \$85,400 (interpolated from Table HC1.7)
- KC = 16.252 (see Table HC1.8)
- L = 110 m
- Assumed cost to upgrade the bridgerail is \$250/m in year 2000 dollars

Present Worth of Collision Costs (PWCC):

$$PWCC = 0.71 \times 1.0 \times 1.0 \times 0.6351 \times 1.60 \times 0.70 \times \$85,400 \times 110 \text{ m} \times 16.252/1000 = \$77,000$$

Present Worth of Upgrading Costs (PWUC):

$$PWUC = 110 \text{ m} \times \$250/\text{m} = \$27,000$$

Total Present Worth (TPW):

$$TPW = \$77,000 + \$27,000 = \$104,000$$

Conclusion: The “Do Nothing” alternative is the recommended alternative because it has the lowest total present worth.

EXAMPLE 3 – BRIDGE #3

BACKGROUND INFORMATION

- highway is a four lane divided highway;
- highway design speed is 110 km/h;
- highway is on tangent horizontal alignment;
- highway is on a vertical curve with a maximum grade less than 2%;
- bridge deck is 9.5 metres above stream bed (water depth less than 3.0 metres);
- minimum bridge shoulder width is 2.5 metres;
- existing bridgerail is a 200 metre long double tube bridgerail on safety curb (typical on both sides of bridge);
- existing approach rail transition is deep-beam guardrail connected to bridgerail;
- AADT is 9900; and
- remaining life of bridge deck and curbs is a minimum of 20 years.

BRIDGERAIL UPGRADING

Alternative 1 “Do-Nothing”

Input Variables:

- $R = 0.48$ (interpolated from Table HC1.1)
- $k_c = 1.0$ (see Table HC1.2)
- $k_g = 1.0$ (see Table HC1.3)
- $P = 0.5849$ (see Table HC1.4)
- $k_m = 1.65$ (see Table HC1.5)
- $k_s = 0.88$ (interpolated from Table HC1.6)
- $SI = 4.0$ (see Figure HC2.1(f), Appendix C2)
- $AC = \$110,800$ (see Table HC1.7)
- $KC = 16.252$ (see Table HC1.8)
- $L = 200$ m

Present Worth of Collision Costs (PWCC):

$$PWCC = 0.48 \times 1.0 \times 1.0 \times 0.5849 \times 1.65 \times 0.88 \times \$110,800 \times 200 \text{ m} \times 16.252/1000 = \$147,000$$

Present Worth of Upgrading Costs (PWUC):

$$PWUC = \$0$$

Total Present Worth (TPW):

$$TPW = \$147,000 + \$0 = \$147,000$$

Alternative 2 "Upgrade Existing Bridgerail Based on Figure HC2.2(l) (Appendix C2)"

Input Variables:

- $R = 0.48$ (interpolated from Table HC1.1)
- $k_c = 1.0$ (see Table HC1.2)
- $k_g = 1.0$ (see Table HC1.3)
- $P = 0.5849$ (see Table HC1.4)
- $k_m = 1.65$ (see Table HC1.5)
- $k_s = 0.88$ (interpolated from Table HC1.6)
- $SI = 3.3$ (see Figure HC2.2(l), Appendix C2)
- $AC = \$85,400$ (interpolated from Table HC1.7)
- $KC = 16.252$ (see Table HC1.8)
- $L = 200 \text{ m}$
- Assumed cost to upgrade the bridgerail is \$300/m in year 2000 dollars

Present Worth of Collision Costs (PWCC):

$$PWCC = 0.48 \times 1.0 \times 1.0 \times 0.5849 \times 1.65 \times 0.88 \times \$85,400 \times 200 \text{ m} \times 16.252/1000 = \$113,000$$

Present Worth of Upgrading Costs (PWUC):

$$PWUC = 200 \text{ m} \times \$300/\text{m} = \$60,000$$

Total Present Worth (TPW):

$$TPW = \$113,000 + \$60,000 = \$173,000$$

Conclusion: The “Do Nothing” alternative is the recommended alternative because it has the lowest total present worth.

APPENDIX C2

EXISTING INFTRA BRIDGERAILS AND CORRESPONDING SEVERITY INDICES

THIS PAGE INTENTIONALLY LEFT BLANK

Appendix C2

Existing INFTRA Bridgerails and Corresponding Severity Indices

TABLE OF CONTENTS

Figure Number	Figure Title	Page Number
Figure HC2.1	Existing INFTRA Bridgerails	H-APP-C2-1
Figure HC2.2-1	Recommended Bridgerail Upgrading Concepts – Sheet 1	H-APP-C2-2
Figure HC2.2-2	Recommended Bridgerail Upgrading Concepts – Sheet 2	H-APP-C2-3

THIS PAGE INTENTIONALLY LEFT BLANK

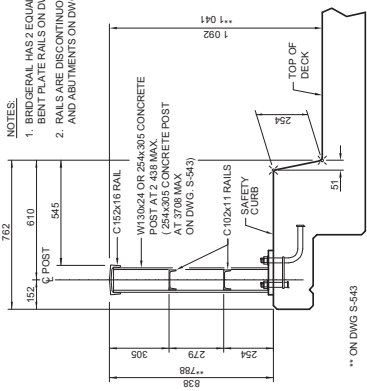

(a) HORIZONTAL RAIL BRIDGE ON SAFETY CURB
(DETAILS SHOWN BASED ON DRAWING S-687)

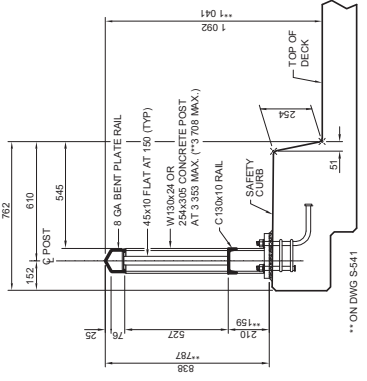

(b) VERTICAL BAR BRIDGE ON SAFETY CURB
(DETAILS SHOWN BASED ON DRAWING S-732)

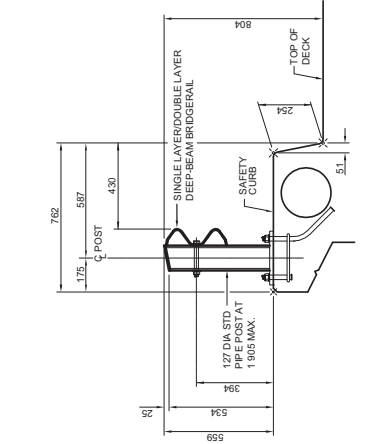

(c) SINGLE LAYER/DOUBLE LAYER DEEP-BEAM BRIDGE ON SAFETY CURB
(DETAILS SHOWN BASED ON DRAWING S-675-68)

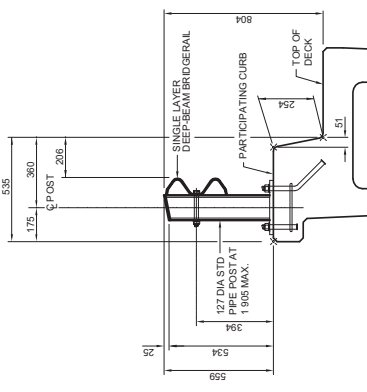

(d) SINGLE LAYER DEEP BEAM BRIDGE ON PARTICIPATING CURB
(DETAILS SHOWN BASED ON DRAWING S-675-68)

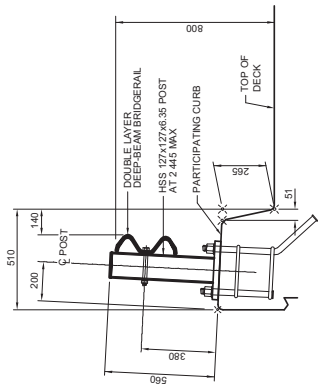

(e) DOUBLE LAYER DEEP BEAM BRIDGE ON PARTICIPATING CURB
(DETAILS SHOWN BASED ON DRAWING S-1402)

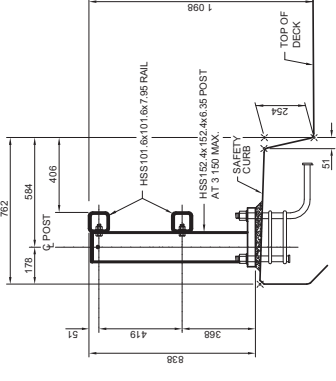

(f) DOUBLE TUBE BRIDGE ON SAFETY CURB
(DETAILS SHOWN BASED ON DRAWING S-966-68)

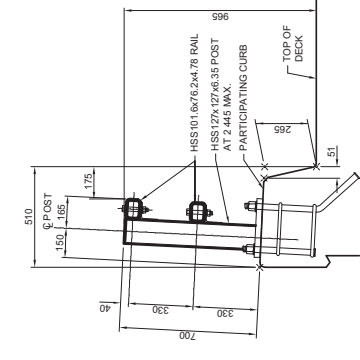

(g) DOUBLE TUBE BRIDGE ON PARTICIPATING CURB
(DETAILS SHOWN BASED ON DRAWING S-1402)

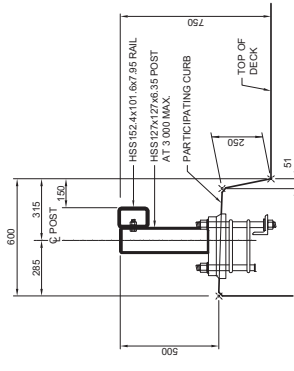

(h) SINGLE TUBE BRIDGE ON PARTICIPATING CURB
(DETAILS SHOWN BASED ON DRAWING S-1618-65)

EXISTING ALBERTA TRANSPORTATION BRIDGES
FIGURE HC2.1

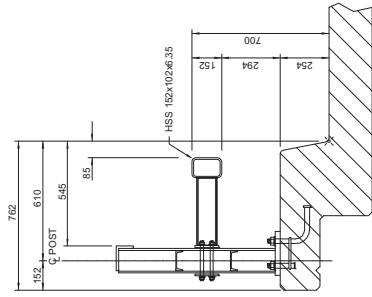

DESIGN SPEED (km/h)	50	60	80	100	110	120
SEVERITY INDEX	2.0	2.1	2.6	3.3	3.6	4.0

**HORIZONTAL RAIL BRIDGE
ON SAFETY CURB
PL-1 UPGRADE WITH HSS BRIDGE RAIL**

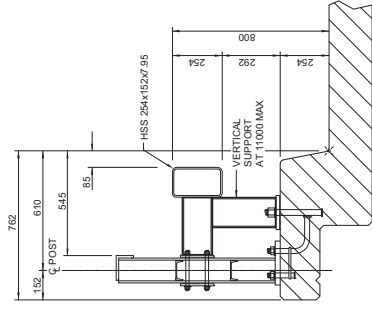

DESIGN SPEED (km/h)	50	60	80	100	110	120
SEVERITY INDEX	2.0	2.1	2.5	3.0	3.3	3.7

**HORIZONTAL RAIL BRIDGE
ON SAFETY CURB
PL-2 UPGRADE WITH HSS BRIDGE RAIL**

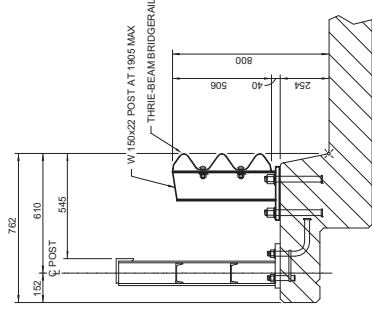

DESIGN SPEED (km/h)	50	60	80	100	110	120
SEVERITY INDEX	2.0	2.1	2.5	3.0	3.3	3.7

**HORIZONTAL RAIL BRIDGE
ON SAFETY CURB
PL-2 UPGRADE WITH THRIE-BEAM BRIDGE RAIL
(SHORT BRIDGES ONLY)**

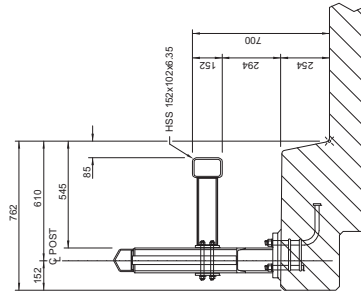

DESIGN SPEED (km/h)	50	60	80	100	110	120
SEVERITY INDEX	2.0	2.1	2.6	3.3	3.6	4.0

**VERTICAL RAIL BRIDGE
ON SAFETY CURB
PL-1 UPGRADE WITH HSS BRIDGE RAIL**

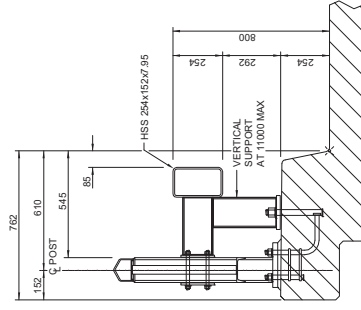

DESIGN SPEED (km/h)	50	60	80	100	110	120
SEVERITY INDEX	2.0	2.1	2.5	3.0	3.3	3.7

**VERTICAL RAIL BRIDGE
ON SAFETY CURB
PL-2 UPGRADE WITH HSS BRIDGE RAIL**

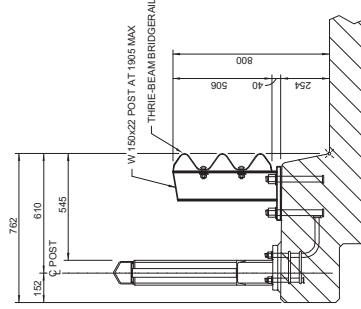

DESIGN SPEED (km/h)	50	60	80	100	110	120
SEVERITY INDEX	2.0	2.1	2.5	3.0	3.3	3.7

**VERTICAL RAIL BRIDGE
ON SAFETY CURB
PL-2 UPGRADE WITH THRIE-BEAM BRIDGE RAIL
(SHORT BRIDGES ONLY)**

RECOMMENDED BRIDGE RAIL UPGRADE CONCEPTS

FIGURE HC2.2-1

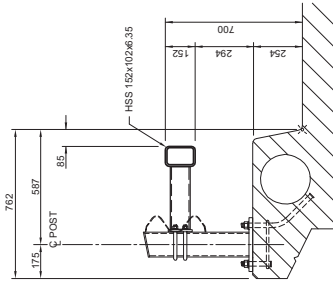

DESIGN SPEED (km/h)	50	60	80	100	110	120
SEVERITY INDEX	2.0	2.1	2.6	3.3	3.6	4.0

(g) SINGLE LAYER/DOUBLE LAYER
DEEP-BEAM BRIDGE RAIL ON SAFETY CURB
PL-1 UPGRADE WITH HSS BRIDGE RAIL

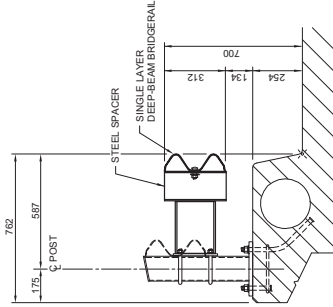

DESIGN SPEED (km/h)	50	60	80	100	110	120
SEVERITY INDEX	2.0	2.1	2.6	3.3	3.6	4.0

(h) SINGLE LAYER/DOUBLE LAYER
DEEP-BEAM BRIDGE RAIL ON SAFETY CURB
PL-1 UPGRADE WITH SINGLE LAYER
DEEP-BEAM BRIDGE RAIL
(SHORT BRIDGES ONLY)

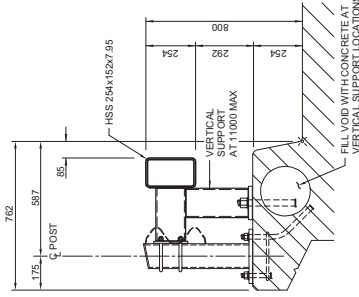

DESIGN SPEED (km/h)	50	60	80	100	110	120
SEVERITY INDEX	2.0	2.1	2.5	3.0	3.3	3.7

(i) SINGLE LAYER/DOUBLE LAYER
DEEP-BEAM BRIDGE RAIL ON SAFETY CURB
PL-2 UPGRADE WITH HSS BRIDGE RAIL

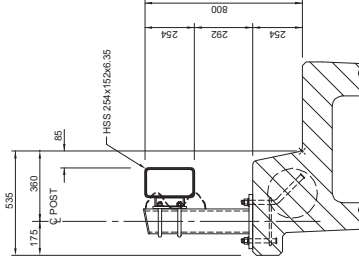

DESIGN SPEED (km/h)	50	60	80	100	110	120
SEVERITY INDEX	2.0	2.1	2.5	3.0	3.3	3.7

(j) SINGLE LAYER DEEP-BEAM
BRIDGE RAIL ON PARTICIPATING CURB
PL-2 UPGRADE WITH HSS BRIDGE RAIL

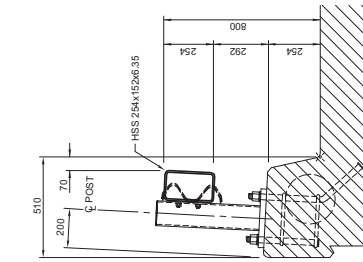

DESIGN SPEED (km/h)	50	60	80	100	110	120
SEVERITY INDEX	2.0	2.1	2.5	3.0	3.3	3.7

(k) DOUBLE LAYER DEEP-BEAM
BRIDGE RAIL ON PARTICIPATING CURB
PL-2 UPGRADE WITH HSS BRIDGE RAIL

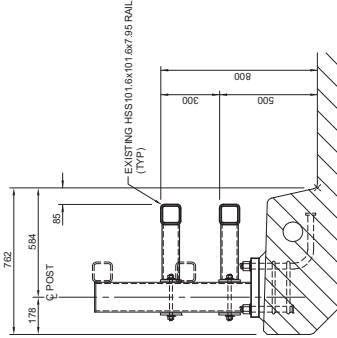

DESIGN SPEED (km/h)	50	60	80	100	110	120
SEVERITY INDEX	2.0	2.1	2.5	3.0	3.3	3.7

(l) DOUBLE TUBE BRIDGE RAIL
ON SAFETY CURB
PL-2 UPGRADE WITH HSS BRIDGE RAIL

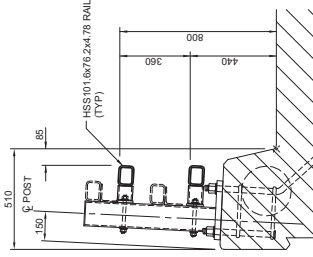

DESIGN SPEED (km/h)	50	60	80	100	110	120
SEVERITY INDEX	2.0	2.1	2.5	3.0	3.3	3.7

(m) DOUBLE TUBE BRIDGE RAIL
ON PARTICIPATING CURB
PL-2 UPGRADE WITH HSS BRIDGE RAIL

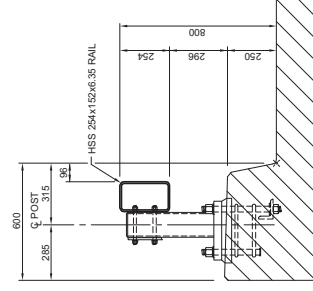

DESIGN SPEED (km/h)	50	60	80	100	110	120
SEVERITY INDEX	2.0	2.1	2.5	3.0	3.3	3.7

(n) SINGLE TUBE BRIDGE RAIL
ON PARTICIPATING CURB
PL-2 UPGRADE WITH HSS BRIDGE RAIL

RECOMMENDED BRIDGE RAIL UPGRADE CONCEPTS

FIGURE HC2.2-2