

SOLAR LED INTEGRATED ARCHITECTURAL AREA LIGHT

Project: _____

Type: _____

Quantity: _____

The IPL series solar LED luminaire is an ideal choice for architectural, commercial, recreational pathway and public space lighting applications. The self-contained, contemporary, rectilinear design smartly embraces modern solar power, adaptive control and LED technologies. With robust construction and unequalled performance, the IPL series is an excellent fit wherever high-quality, full-cutoff lighting and minimal visual clutter is required.

Using solar power and LEDs, the IPL is completely self-contained and offers significant benefits over grid-based lights including:

- Cost-effective design that ships fully assembled and installs in minutes
- Wireless control & communication with your light
- Low installation cost and minimal site impact with no trenching, cabling or wiring
- Minimal ongoing costs with no electrical bills or bulbs to change
- Operates entirely independent from the grid and is immune to power outages
- A sustainable choice without recurring carbon emissions

All of our solar powered lights are enabled by our innovative Solar Lighting Controller (SLC). The SLC in each light is “self-learning” and allows the lights to predictively adapt to their surroundings, providing a level of lighting performance and reliability unavailable in other solar lighting products.



WIRELESS
CONTROL APP

TECHNICAL SPECIFICATIONS

- Solar Module:**
- High-efficiency monocrystalline cells
 - Inconspicuously integrated into the top of luminaire
 - Used for day/night detection (no photocell required)

- Solar Lighting Controller (SLC):**
- High-efficiency Maximum Power Point Tracking (MPPT)
 - Microcontroller based technology
 - Includes high-efficiency LED driver
 - Multiyear data logging
 - Integrated into luminaire housing
 - Designed to automatically manage lighting performance based on environmental conditions and lighting requirements
 - Potted weatherproof construction

- Battery:**
- High-performance lithium (LiFePO₄)
 - Exceptional 10+ year lifecycle
 - High-temperature tolerance
 - Contained within luminaire housing
 - Designed for easy battery changes when required

- LEDs and Optics:**
- 100,000 hour L70 lifetime
 - Extra Warm White (2700K), Warm White (3000K), Neutral White (4000K), and Amber (595nm) LEDs available
 - High-efficiency type 2, 3, 4, 4F, and 5, full cut-off optics
 - Typical lumen output of 1250 lumens
 - Optional backlight shield
 - Wildlife-friendly amber option available

- Mechanical Construction:**
- Cast, low copper aluminum design
 - Stainless fasteners with security fastener option
 - Architectural grade, super durable, TGIC powder coat
 - Four standard colors with custom colors available

- Lighting Profiles:**
- 11 standard profiles options
 - Real-time based lighting profiles available
 - See lighting profile sheet for all options
 - Motion sensing capabilities optimize performance based usage
 - Lighting profiles and motion sensing options are field configurable with app

- Wireless Controls:**
- Bluetooth low energy interface with iOS app
 - Provide configuration and control of lighting profiles
 - Adjust dusk and dawn thresholds
 - Motion sensing capabilities optimize performance based on usage

SOLAR LED INTEGRATED ARCHITECTURAL AREA LIGHT

EPA: 0.65ft² (0.06m²) | Weight: 24.7 lbs (11.2 kg) including battery

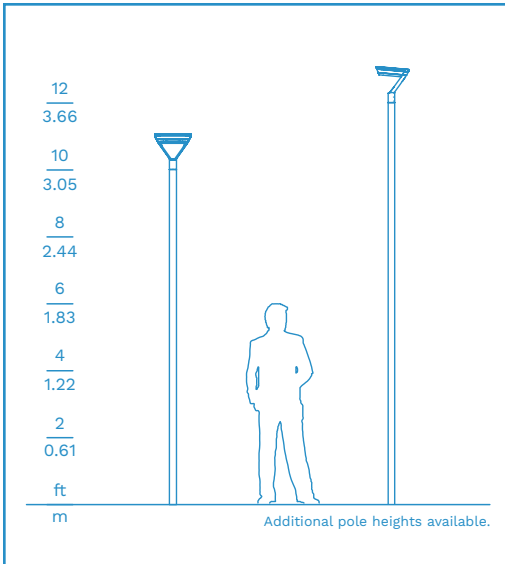
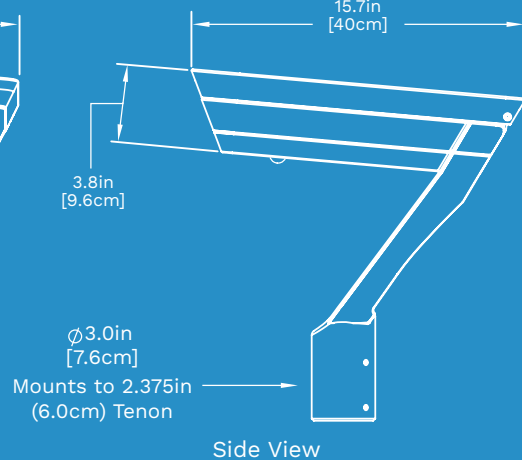
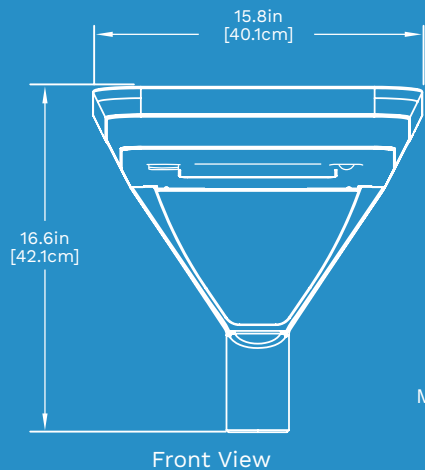

PHOTOMETRICS (IES files available on website)

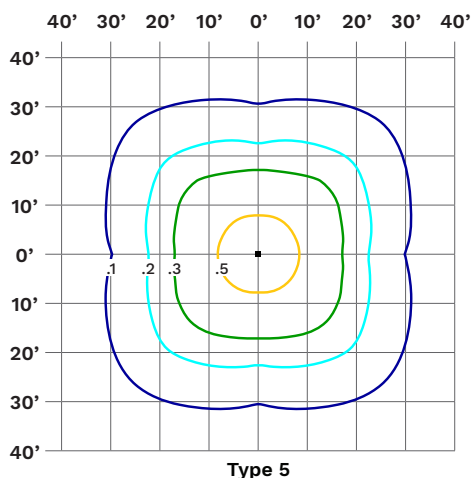
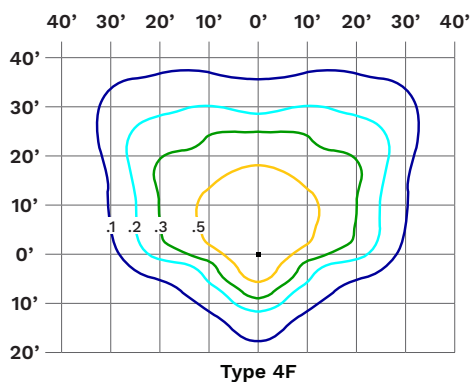
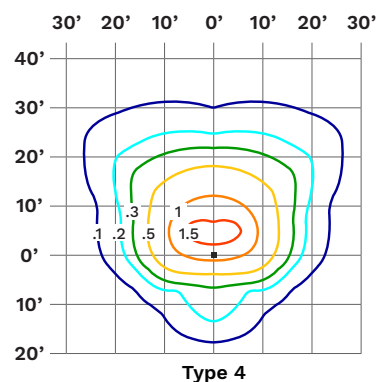
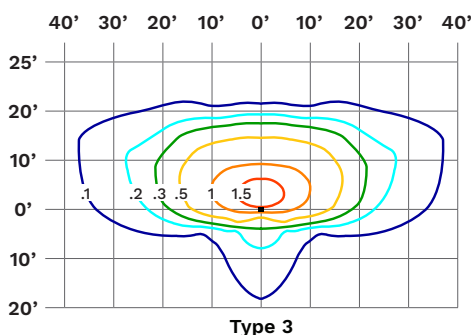
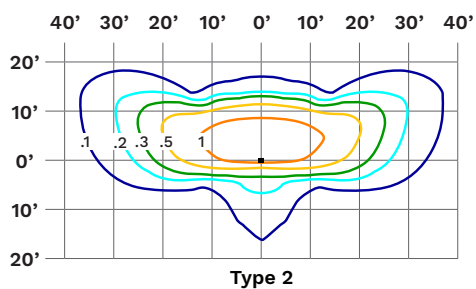

Notes:

- Photometrics based on 12 ft mounting height
- Light levels in foot candles are calculated using 1250 lumens at 4000K color temperature
- To convert to lux multiply light levels by 10.7
- Typical lumen levels based off of Type 5 optic with the default profile using neutral white LEDs
- Contact us for help in choosing the right lighting profile and distribution
- Motion sensing is ON by default
- Specifications subject to change without notice

ORDER MATRIX

Series	Mounting	Finish	Distribution	LED	Lighting Profile (Full list on website)	Options
IPL	PTM - Post Top Mount	BK - Black	T2 - Type 2	XW - 2700K	00 - Dusk till dawn	SEC - Security Fasteners
		BZ - Bronze	T3 - Type 3	WW - 3000K	09 - On at dusk, 100% for 3 hours, dim to 30%, brighten to 100% one hour before dawn, off at dawn (DEFAULT)	MSO - Motion Sensor Off
		SV - Silver	T4 - Type 4	NW - 4000K		BLS - Backlight Shield
		WH - White	T4F - Type 4F	AMB - Amber	TX0000 - On at dusk until time between 1800 & 0600. X = O (Off) or D (Dim). 0000 = time to dim or turn off.	
		CC - Custom	T5 - Type 5			

